



DATE 1 October, 2013

No. V-70001

Messrs. _____

SPECIFICATION

Model: AP2, AG2 Pressure Sensor

Project: _____

Distributor: _____

Reference: _____

A handwritten signature in black ink, appearing to read 'Y. Uchiumi', is written over a horizontal line.

Yoshiyuki Uchiumi, Application Engineer
Sensor Department Fujikura Ltd.

Fujikura Ltd.

Table of Contents

1. General.....	2
2. Principle.....	2
3. Device Lineup.....	2
4. RoHS	2
5. Block Diagram and Pin Connections.....	3
6. Device Name Code.....	4
7. Absolute Maximum Ratings.....	4
8. General Specifications	5
9. Pressure Range	5
10. Electrical Characteristics	6
11. Output versus Input Pressure.....	8
12. Transfer Function	9
13. Device Marking	10
14. Soldering.....	11
15. Dimensions and Weights.....	11
16. Ordering Information.....	12
17. Tape & Reel Information.....	12
18. Footprint for PCB (for Reference).....	13
19. Notes.....	14
Appendix: Dimension Drawing	15
9-772-001 APxxN	15
9-772-002 APxxR	16
9-772-003 AGxx3	17
9-772-004 AGxx6	18

1. General

This document describes the specifications of Fujikura Pressure Sensors, AP2 and AG2 series.

2. Principle

Fujikura Pressure Sensor is composed of a silicon piezoresistive pressure sensing chip and a signal conditioning integrated circuit. The low-level signal from the sensing chip is amplified, temperature compensated, calibrated, and finally converted to a high-level output signal that is proportional to the applied pressure.

3. Device Lineup

This device has the following lineup.

Model	Pressure Type	Supply Voltage	Accuracy	Pressure Range (kPa)									
				-100	-50	0	25	50	100	200	500	1000	
AP2 or AG2	Gauge	5.0 Vdc or 3.3 Vdc	±1.5 %FS										
		3.0 Vdc	±2.0 %FS	Same as the above									

Features

- ✓ Low power consumption
- ✓ High accuracy
- ✓ Pins & Package compatible with XFPM & XFGM integrated pressure sensor
- ✓ Customization available

Applications

- ✓ Battery-operated devices
- ✓ Medical devices
- ✓ Industrial pneumatic devices
- ✓ Consumer devices

4. RoHS

This device is compliant with the Restriction of the use of certain Hazardous Substances in Electrical and Electronic Equipment (RoHS).

Table shown below is revision records of this specification

Rev.	Date	Name	Comment	Mark
Est.	1 Oct., 2013	Y.Uchiumi		

5. Block Diagram and Pin Connections

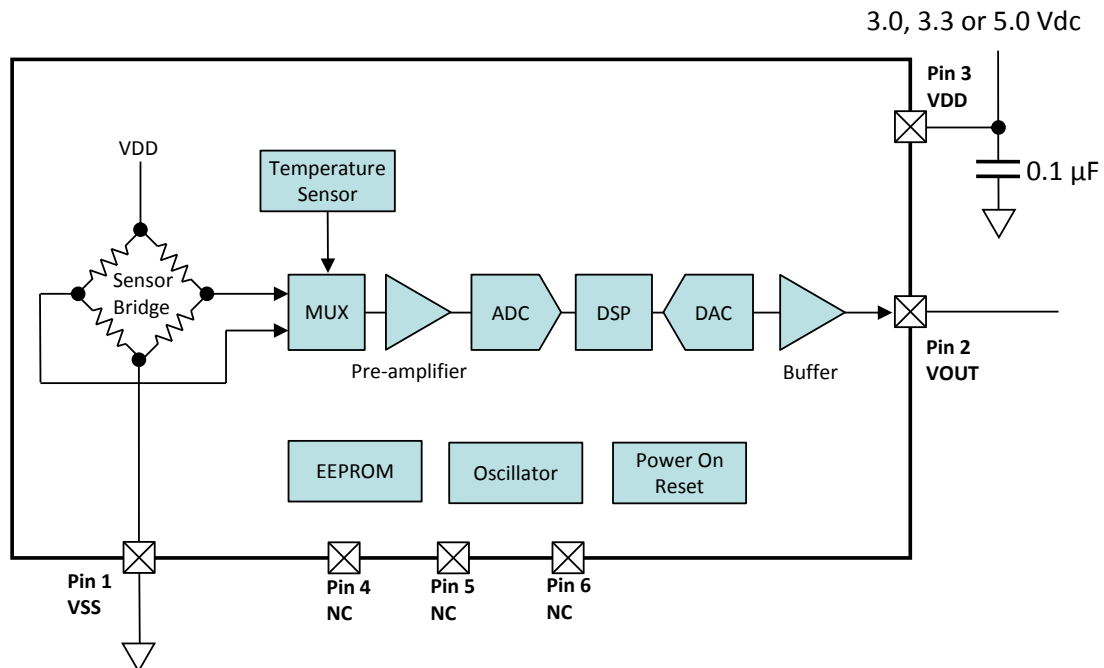

Pin Assignment		Pin No.	Pin Name	I/O	Type	Function
AP2	AG2					
		1	VSS	-	-	Common voltage connection
		2	VOUT	O	Analog	Analog output
		3	VDD	-	-	Power supply connection
		4	NC	-	-	-
		5	NC	-	-	-
		6	NC	-	-	-

*1
*2
*2
*2

Notes:

- *1) Put a 0.1 μ F capacitor between VDD Pin 3 and VSS Pin 1.
- *2) Pin 4, 5 and 6 must be open.

6. Device Name Code

The device name code is consisted of Sensor code, Pressure code, Custom ID and Packing style. For the exact ordering device number, please refer to Chapter 16 Ordering Information.

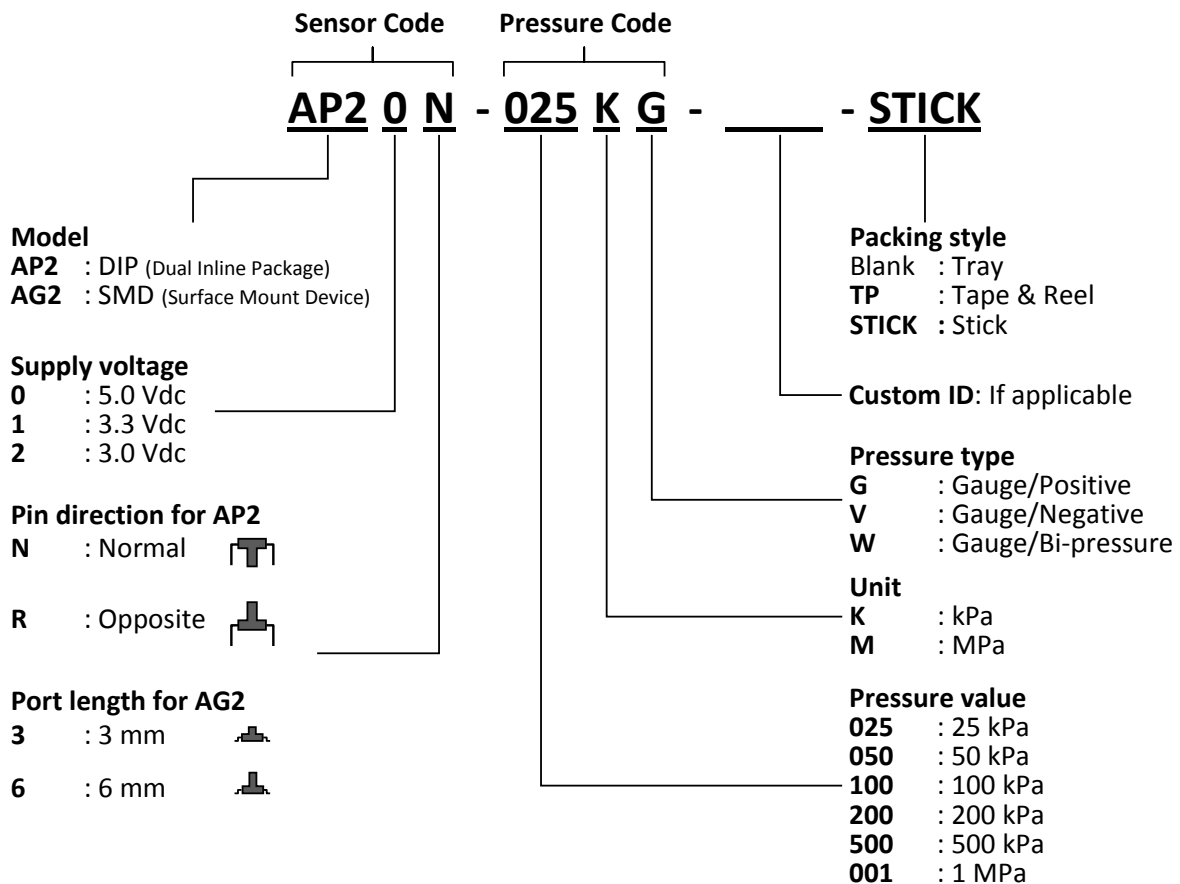

7. Absolute Maximum Ratings

Item	Symbol	Rating	Unit	
Load Pressure	Pressure Code Pmax+	025KG	+50	kPa
		050KG	+100	kPa
		100KG	+200	kPa
		200KG	+400	kPa
		500KG	+1	MPa
		001MG	+1.5	MPa
		50KV	+100	kPa
		100KV	+200	kPa
		100KW	+200	kPa
Supply Voltage	VDDmax	6	Vdc	
Operating Temperature	Topt	-40 to +125	deg. C	
Storage Temperature	Tstg	-40 to +125	deg. C	

Note:

*1) Absolute maximum ratings are the limits that the device will withstand without damage.

V-70001**8. General Specifications**

Item	Sensor Code		AP20x AG20x	AP21x AG21x	AP22x AG22x	Unit
	Symbol					
Supply Voltage	VDD		5.0±0.25	3.3±0.165	3.0±0.15	Vdc
Type of Pressure	-	Gauge pressure				
Pressure Media	-	Non-corrosive gases				
Pressure Range	Popt	Refer to Chapter 9				
Compensated Temperature	-	0 to +85				deg. C
Operating Humidity	Hopt	30 to 85 (non-condensing)				%RH
Storage Humidity	Hstg	30 to 85 (non-condensing)				%RH
Dielectric Strength		Leakage current 1mA maximum, AC 500 V, 1 minute				
Insulation Resistance		100 MΩ minimum (DC 500 V)				

Notes:

- *1) Output voltage (Vout) is not perfectly ratio-metric with Supply voltage (VDD).
- *2) Gauge pressure is defined as the difference between the pressure applied to the pressure port and an atmospheric pressure of the device.
- *3) Ensure the pressure media contains no particulates. The device is not compatible with liquids.
- *4) Please also refer to Chapter 12 Transfer Function.
- *5) Do not wet the device with dew.
- *6) Dielectric strength is defined as the leakage current between all pins and the package with AC 500 V, 1 minute.
- *7) Insulation resistance is defined as the resistance value between all pins and the package with DC 500 V.

9. Pressure Range

Pressure Code	Symbol	Pressure Range *1			Unit
		Min.	Typ.	Max.	
025KG	Popt	0	-	+25	kPa
050KG		0	-	+50	kPa
100KG		0	-	+100	kPa
200KG		0	-	+200	kPa
500KG		0	-	+500	kPa
001MG		0	-	+1	MPa
050KV		-50	-	0	kPa
100KV		-100	-	0	kPa
100KW		-100	-	+100	kPa

Note:

- *1) Pressure range is defined as the measurable pressure range of the device. Do not expose intentionally beyond minimum Popt and maximum Popt.

V-70001

10. Electrical Characteristics

Load resistor $R_L = \infty$, Ambient temperature $T_a = 25$ deg. C

Item	Condition	Symbol	Rating			Unit	
			Min.	Typ.	Max.		
Sensor Code: AP20x, AG20x (VDD = 5.0 Vdc)							
Offset Voltage	Min. Popt, 050KV & 100KV: Max. Popt	Voff	0.1325	0.2	0.2675	V	*1, 2
Full Scale Voltage	Max. Popt, 050KV & 100KV: Min. Popt	Vfs	4.6325	4.7	4.7675	V	*3
Span Voltage	Min. to max. Popt	SV	-	4.5	-	V	*4
Accuracy	0 to 85 deg. C	Error	-1.5	-	+1.5	%FS	*5, 6
			-0.0675	-	+0.0675	V	
Output Resolution		Vrso	-	2.5	-	mV	*7
Supply Current		Ic	-	-	3	mAdc	*8
Sensor Code: AP21x, AG21x (VDD = 3.3 Vdc)							
Offset Voltage	Min. Popt, 050KV & 100KV: Max. Popt	Voff	0.2595	0.3	0.3405	V	*1, 2
Full Scale Voltage	Max. Popt, 050KV & 100KV: Min. Popt	Vfs	2.9595	3.0	3.0405	V	*3
Span Voltage	Min. to max. Popt	SV	-	2.7	-	V	*4
Accuracy	0 to 85 deg. C	Error	-1.5	-	+1.5	%FS	*5, 6
			-0.0405	-	+0.0405	V	
Output Resolution		Vrso	-	1.7	-	mV	*7
Supply Current		Ic	-	-	2	mAdc	*8
Sensor Code: AP22x, AG22x (VDD = 3.0 Vdc)							
Offset Voltage	Min. Popt, 050KV & 100KV: Max. Popt	Voff	0.096	0.15	0.204	V	*1, 2
Full Scale Voltage	Max. Popt, 050KV & 100KV: Min. Popt	Vfs	2.796	2.85	2.904	V	*3
Span Voltage	Min. to max. Popt	SV	-	2.7	-	V	*4
Accuracy	0 to 85 deg. C	Error	-2.0	-	+2.0	%FS	*5, 6
			-0.054	-	+0.054	V	
Output Resolution		Vrso	-	1.5	-	mV	*7
Supply Current		Ic	-	-	2	mAdc	*8
Response Time	for reference	tr	-	1	-	msec.	*9
Sampling Frequency		fs	-	1	-	kHz	*10
Load Resistor	VOUT - VSS or VDD - VOUT	RL	2.5	-	-	k Ω	*8
Load Capacitance	VOUT - VSS	CL	-	-	15	nF	*11

Notes;

- *1) Offset voltage (Voff) is defined as the output voltage at minimum Popt. In case of 100KV, Offset voltage (Voff) is defined as the output voltage of maximum Popt.
- *2) Offset error is calibration error of Offset voltage (Voff) at production. It does not include Long term offset drift. It would be suggested that applications have Auto-zeroing function.
- *3) Full scale voltage (Vfs) is defined as the output voltage at maximum Popt. In case of 100KV, Full scale voltage (Vfs) is defined as the output voltage of minimum Popt.
- *4) Output span voltage (SV) is defined as the voltage difference between Offset voltage (Voff) and Full scale voltage (Vfs).

- *5) Accuracy consists of the following:
 Non-linearity
 Temperature errors over the temperature range 0 to 85 degree C
 Pressure hysteresis
 Calibration errors of sensitivity and offset
- *6) The unit of Accuracy “%FS” is defined as a percent error by Span voltage (SV).
- *7) Output voltage (Vout) is generated by the internal digital to analog converter. Therefore the output voltage has Output resolution (Vrso). Resolution in pressure is calculated as below:

$$\text{Pressure resolution} = \frac{V_{rso}}{SV} \times \text{Pressure range (Min. to Max.)}$$

- *8) Supply Current (Ic) is increased depending on the value of Load resistor (RL).
- *9) Response time (tr) is defined as the time for the change in Output voltage (Vout) from 10 % to 90 % or from 90 % to 10 % of its final value when the input pressure makes a step change.

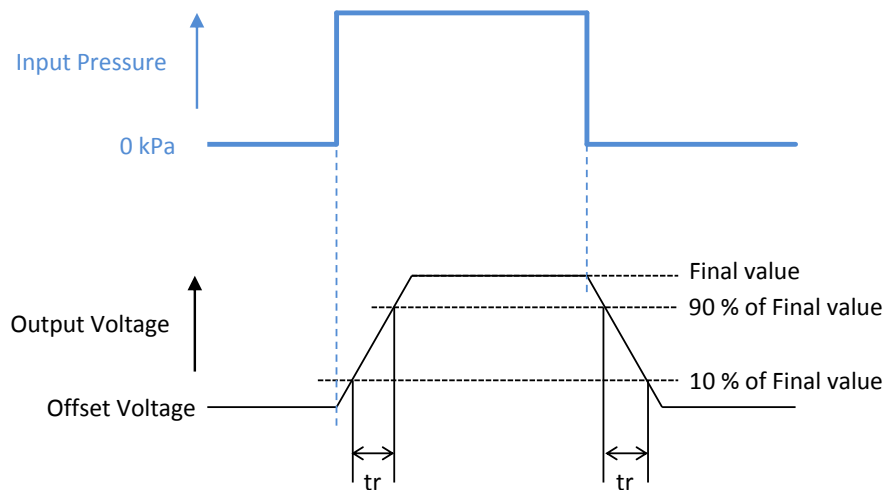

- *10) Output voltage (Vout) is sampled and held by the internal sampling / hold block. Sampling frequency (fs) is 1 kHz. The output voltage is changed stepwise every approximately 1 millisecond.

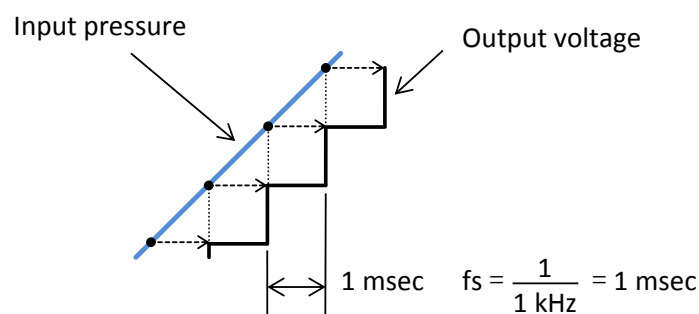

- *11) Do not directly connect Load capacitance (CL) that is over 15 nF to VOUT.

11. Output versus Input Pressure

Sensor Code	Pressure Code		
	025KG, 050KG, 100KG, 200KG, 500KG, 001MG	050KV, 100KV	100KW
AP20x AG20x	<p>VDD = 5.0 Vdc Temp. = 0 to 85°C</p> <p>Output</p> <p>Vfs: 4.7 V</p> <p>Error: $\pm 1.5\%FS$</p> <p>Voff: 0.2 V</p> <p>SV: 4.5 V</p> <p>Min. Popt: 0 kPa</p> <p>Max. Popt: 25, 50, 100, 200 kPa, 1 MPa</p> <p>Input Pressure</p>	<p>VDD = 5.0 Vdc Temp. = 0 to 85°C</p> <p>Output</p> <p>Vfs: 4.7 V</p> <p>Error: $\pm 1.5\%FS$</p> <p>Voff: 0.2 V</p> <p>SV: 4.5 V</p> <p>Min. Popt: -100 kPa</p> <p>Max. Popt: 0 kPa</p> <p>Input Pressure</p>	<p>VDD = 5.0 Vdc Temp. = 0 to 85°C</p> <p>Output</p> <p>Vfs: 4.7 V</p> <p>Error: $\pm 1.5\%FS$</p> <p>Voff: 0.2 V</p> <p>SV: 4.5 V</p> <p>Min. Popt: -100 kPa</p> <p>Max. Popt: 0 kPa, +100 kPa</p> <p>Input Pressure</p>
AP21x AG21x	<p>VDD = 3.3 Vdc Temp. = 0 to 85°C</p> <p>Output</p> <p>Vfs: 3.0 V</p> <p>Error: $\pm 1.5\%FS$</p> <p>Voff: 0.3 V</p> <p>SV: 2.7 V</p> <p>Min. Popt: 0 kPa</p> <p>Max. Popt: 25, 50, 100, 200 kPa, 1 MPa</p> <p>Input Pressure</p>	<p>VDD = 3.3 Vdc Temp. = 0 to 85°C</p> <p>Output</p> <p>Vfs: 3.0 V</p> <p>Error: $\pm 1.5\%FS$</p> <p>Voff: 0.3 V</p> <p>SV: 2.7 V</p> <p>Min. Popt: -100 kPa</p> <p>Max. Popt: 0 kPa</p> <p>Input Pressure</p>	<p>VDD = 3.3 Vdc Temp. = 0 to 85°C</p> <p>Output</p> <p>Vfs: 3.0 V</p> <p>Error: $\pm 1.5\%FS$</p> <p>Voff: 0.3 V</p> <p>SV: 2.7 V</p> <p>Min. Popt: -100 kPa</p> <p>Max. Popt: 0 kPa, +100 kPa</p> <p>Input Pressure</p>
AP22x AG22x	<p>VDD = 3.0 Vdc Temp. = 0 to 85°C</p> <p>Output</p> <p>Vfs: 2.85 V</p> <p>Error: $\pm 2.0\%FS$</p> <p>Voff: 0.15 V</p> <p>SV: 2.7 V</p> <p>Min. Popt: 0 kPa</p> <p>Max. Popt: 25, 50, 100, 200 kPa, 1 MPa</p> <p>Input Pressure</p>	<p>VDD = 3.0 Vdc Temp. = 0 to 85°C</p> <p>Output</p> <p>Vfs: 2.85 V</p> <p>Error: $\pm 2.0\%FS$</p> <p>Voff: 0.15 V</p> <p>SV: 2.7 V</p> <p>Min. Popt: -100 kPa</p> <p>Max. Popt: 0 kPa</p> <p>Input Pressure</p>	<p>VDD = 3.0 Vdc Temp. = 0 to 85°C</p> <p>Output</p> <p>Vfs: 2.85 V</p> <p>Error: $\pm 2.0\%FS$</p> <p>Voff: 0.15 V</p> <p>SV: 2.7 V</p> <p>Min. Popt: -100 kPa</p> <p>Max. Popt: 0 kPa, +100 kPa</p> <p>Input Pressure</p>

12. Transfer Function

$$V_{out} = VDD \times ((P \times \alpha) + \beta) \pm (\text{Pressure Error} \times \text{Temperature Error Multiplier} \times \alpha \times VDD)$$

Parameters

Sensor Code	Parameter		VDD (*1)	P (kPa)	α	β	Pressure Error (kPa)
		Pressure Code					
AP20x AG20x		025KG	5.0±0.25 V	0 ~ +25	9/250	1/25	0.375
		050KG		0 ~ +50	9/500	1/25	0.75
		100KG		0 ~ +100	9/1000	1/25	1.5
		200KG		0 ~ +200	9/2000	1/25	3.0
		500KG		0 ~ +500	9/5000	1/25	7.5
		001MG		0 ~ +1000	9/10000	1/25	15
		050KV		-50 ~ 0	-9/500	1/25	0.75
		100KV		-100 ~ 0	-9/1000	1/25	1.5
		100KW		-100 ~ +100	9/2000	49/100	3.0
AP21x AG21x		025KG	3.3±0.165 V	0 ~ +25	297/9075	1/11	0.375
		050KG		0 ~ +50	297/18150	1/11	0.75
		100KG		0 ~ +100	297/36300	1/11	1.5
		200KG		0 ~ +200	297/72600	1/11	3.0
		500KG		0 ~ +500	297/181500	1/11	7.5
		001MG		0 ~ +1000	297/363000	1/11	15
		050KV		-50 ~ 0	-297/18150	1/11	0.75
		100KV		-100 ~ 0	-297/36300	1/11	1.5
		100KW		-100 ~ +100	27/6600	1/2	3.0
AP22x AG22x		025KG	3.0±0.15 V	0 ~ +25	9/250	1/20	0.5
		050KG		0 ~ +50	9/500	1/20	1
		100KG		0 ~ +100	9/1000	1/20	2
		200KG		0 ~ +200	9/2000	1/20	4
		500KG		0 ~ +500	9/5000	1/20	10
		001MG		0 ~ +1000	9/10000	1/20	20
		050KV		-50 ~ 0	-9/500	1/20	1
		100KV		-100 ~ 0	-9/1000	1/20	2
		100KW		-100 ~ +100	9/2000	1/2	4

*1) Output voltage (V_{out}) is not perfectly ratio-metric with the supply voltage (VDD).

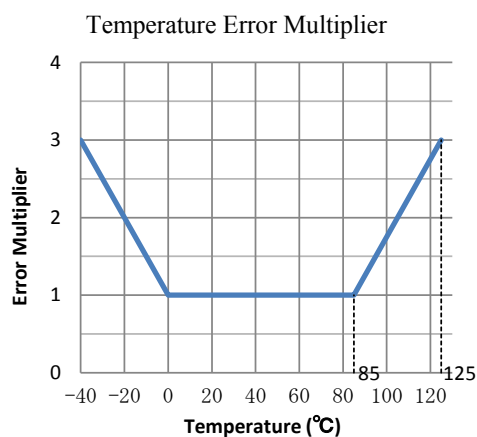

13. Device Marking

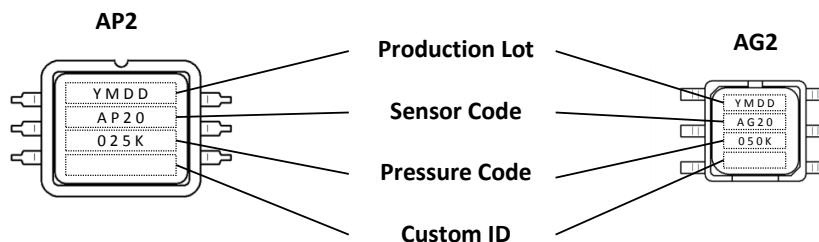

Items		Marking
Production Lot		
Y	Last digit of Production year	0~9
M	Production month	1, 2, 3 ~ 8, 9, X=Oct., Y=Nov., Z=Dec.
DD	Production date	01~31
Sensor Code		
	AP20x	AP20
	AP21x	AP21
	AP22x	AP22
	AG20x	AG20
	AG21x	AG21
	AG22x	AG22
Pressure Code		
	025KG	025K
	050KG	050K
	100KG	100K
	200KG	200K
	500KG	500K
	001MG	001M
	050KV	050V
	100KV	100V
	100KW	100W
Custom ID		If applicable

*1

*2

Notes:

*1) Pin direction for AP2 or Port length for AG2 is not marked on the face plate.

*2) Custom ID will be added when a product is customized for a customer.

V-70001

14. Soldering

Process	Sensor code	Condition																		
Hand Soldering	AP2xx	Soldering iron temperature: 350 deg. C max. Soldering time: 3 seconds max.																		
Wave Soldering	AP2xR	Soldering bath temperature: 260 deg. C max. Soldering time: 5 seconds max.																		
Reflow Soldering	AG2xx	<p style="text-align: center;">Soldering Profile</p> <table border="1" style="margin-top: 10px;"> <thead> <tr> <th></th> <th></th> <th></th> </tr> </thead> <tbody> <tr> <td>A</td> <td>Ramp up</td> <td>2 to 4 deg. C / sec.</td> </tr> <tr> <td>B</td> <td>Pre-heating</td> <td>150 to 180 deg. C 60 to 120 sec.</td> </tr> <tr> <td>C</td> <td>Ramp up</td> <td>2 to 4 deg. C / sec.</td> </tr> <tr> <td>D</td> <td>Heating</td> <td>Above 230 deg. C, 45 sec. max. 245 deg. C max., 10 sec. max.</td> </tr> <tr> <td>E</td> <td>Ramp down</td> <td>2 to 4 deg. C / sec.</td> </tr> </tbody> </table>				A	Ramp up	2 to 4 deg. C / sec.	B	Pre-heating	150 to 180 deg. C 60 to 120 sec.	C	Ramp up	2 to 4 deg. C / sec.	D	Heating	Above 230 deg. C, 45 sec. max. 245 deg. C max., 10 sec. max.	E	Ramp down	2 to 4 deg. C / sec.
A	Ramp up	2 to 4 deg. C / sec.																		
B	Pre-heating	150 to 180 deg. C 60 to 120 sec.																		
C	Ramp up	2 to 4 deg. C / sec.																		
D	Heating	Above 230 deg. C, 45 sec. max. 245 deg. C max., 10 sec. max.																		
E	Ramp down	2 to 4 deg. C / sec.																		

*1, 2

*1, 2

*1, 2,
3, 4

Notes:

- *1) NEVER wash the device with any washing liquid. NEVER wash the device with any ultrasonic washing machine.
- *2) Do not put the solder and flux on the device's package.
- *3) Temperature means Surface temperature of the device's package.
- *4) Reflow soldering is within two times.

15. Dimensions and Weights

Refer to the following drawing as attached.

Sensor Code	Dimension Drawing	Weight
AP2xN	9-772-001	approx. 1.4 grams
AP2xR	9-772-002	
AG2x3	9-772-003	approx. 0.3 grams
AG2x6	9-772-004	approx. 0.4 grams

16. Ordering Information

Model	Package	Supply Voltage	Pin Direction	Packing	Ordering Device Number	Qty./Packing	
AP2	DIP	5.0 Vdc	Normal	Tray	AP20N- [Pressure Code]	150 Pcs/Tray	
				Stick	AP20N- [Pressure Code] -STICK	40 Pcs/Stick	
			Opposite	Tray	AP20R- [Pressure Code]	150 Pcs/Tray	
				Stick	AP20R- [Pressure Code] -STICK	40 Pcs/Stick	
			3.3 Vdc	Normal	Tray	AP21N- [Pressure Code]	150 Pcs/Tray
					Stick	AP21N- [Pressure Code] -STICK	40 Pcs/Stick
		Opposite	Tray	AP21R- [Pressure Code]	150 Pcs/Tray		
			Stick	AP21R- [Pressure Code] -STICK	40 Pcs/Stick		
		3.0 Vdc	Normal	Tray	AP22N- [Pressure Code]	150 Pcs/Tray	
				Stick	AP22N- [Pressure Code] -STICK	40 Pcs/Stick	
			Opposite	Tray	AP22R- [Pressure Code]	150 Pcs/Tray	
				Stick	AP22R- [Pressure Code] -STICK	40 Pcs/Stick	
			Port Length				
AG2	SMD		5.0 Vdc	3 mm	Tray	AG203- [Pressure Code]	300 Pcs/Tray
		Tape & Reel			AG203- [Pressure Code] -TP	500 Pcs/Reel	
		6 mm		Tray	AG206- [Pressure Code]	300 Pcs/Tray	
				Tape & Reel	AG206- [Pressure Code] -TP	500 Pcs/Reel	
		3.3 Vdc	3 mm	Tray	AG213- [Pressure Code]	300 Pcs/Tray	
				Tape & Reel	AG213- [Pressure Code] -TP	500 Pcs/Reel	
			6 mm	Tray	AG216- [Pressure Code]	300 Pcs/Tray	
				Tape & Reel	AG216- [Pressure Code] -TP	500 Pcs/Reel	
		3.0 Vdc	3 mm	Tray	AG223- [Pressure Code]	300 Pcs/Tray	
				Tape & Reel	AG223- [Pressure Code] -TP	500 Pcs/Reel	
			6 mm	Tray	AG226- [Pressure Code]	300 Pcs/Tray	
				Tape & Reel	AG226- [Pressure Code] -TP	500 Pcs/Reel	



Pressure Range	Pressure Code
0 ~ +25 kPa	025KG
0 ~ +50 kPa	050KG
0 ~ +100 kPa	100KG
0 ~ +200 kPa	200KG
0 ~ +500 kPa	500KG
0 ~ +1 MPa	001MG
-50 ~ 0 kPa	050KV
-100 ~ 0 kPa	100KV
-100 ~ +100 kPa	100KW

17. Tape & Reel Information

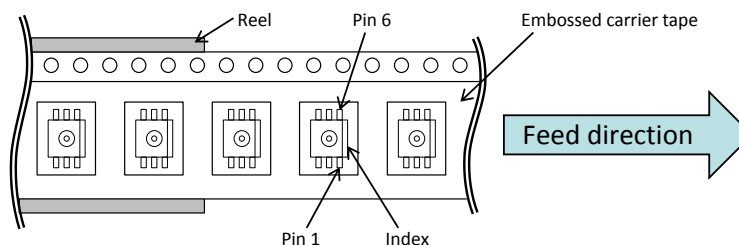

18. Footprint for PCB (for Reference)

Sensor Code	Footprint
AP2xN	
AP2xR	
AG2x3	
AG2x6	

Notes:

*1) These footprints are for reference. Please evaluate well these footprints, before your mass production.

*2) When designing your PCB, please also refer to the outline diagrams.

19. Notes

- Fujikura reserves all rights.
- This document has a possibility to be changed without notice.
- Limitation, usage, environment, standard warranty and so on are listed on Fujikura web site.
- Please refer to the latest specifications.



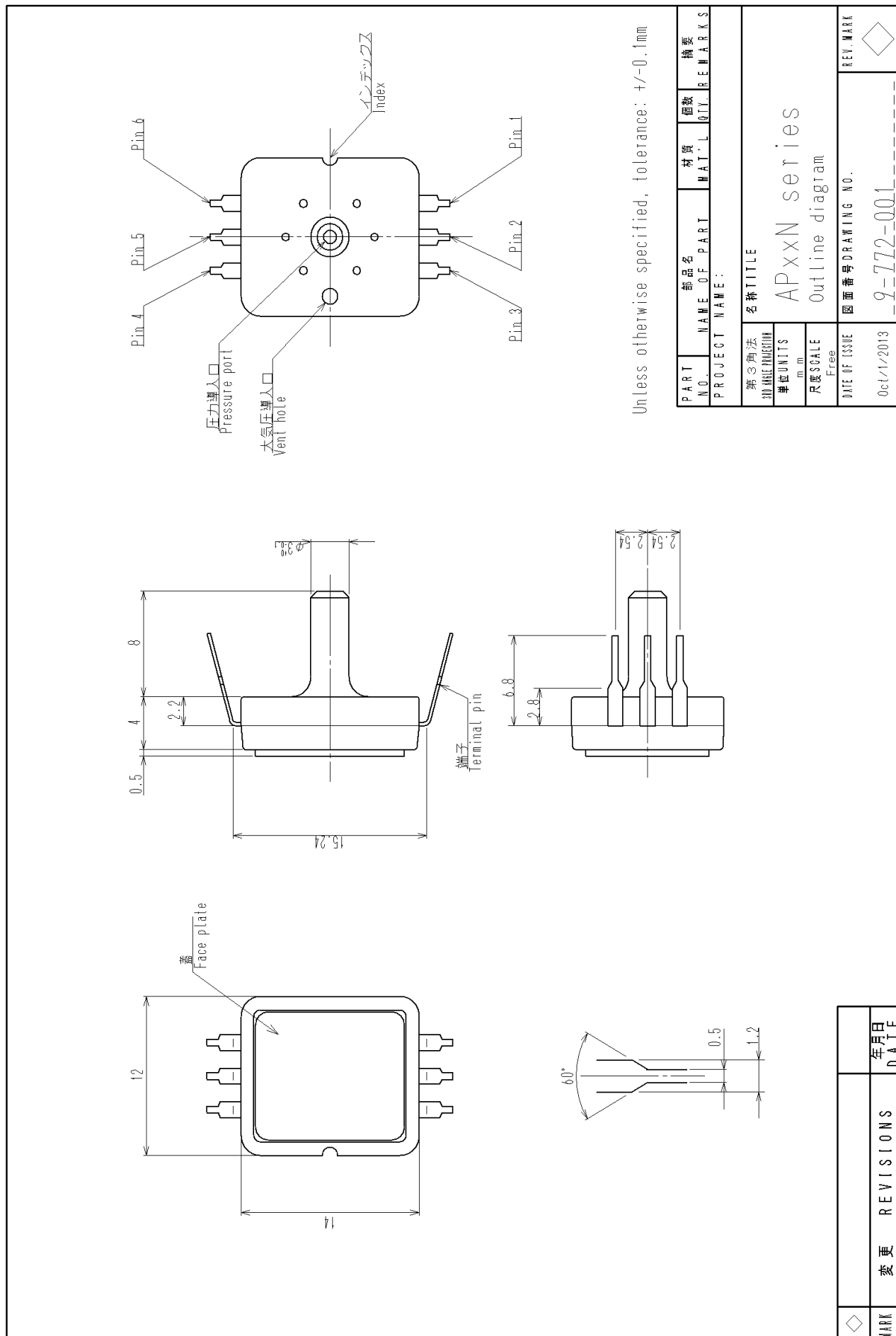

PART NO.	部品名	材質	個数	備考
PROJECT NAME:				
名称TITLE				
APxxN series				
Outline diagram				
図面番号DRAWING NO.				
9-772-001				
REV. MARK				
◇				

MARK	変更	REVISIONS	年月日
			DATE

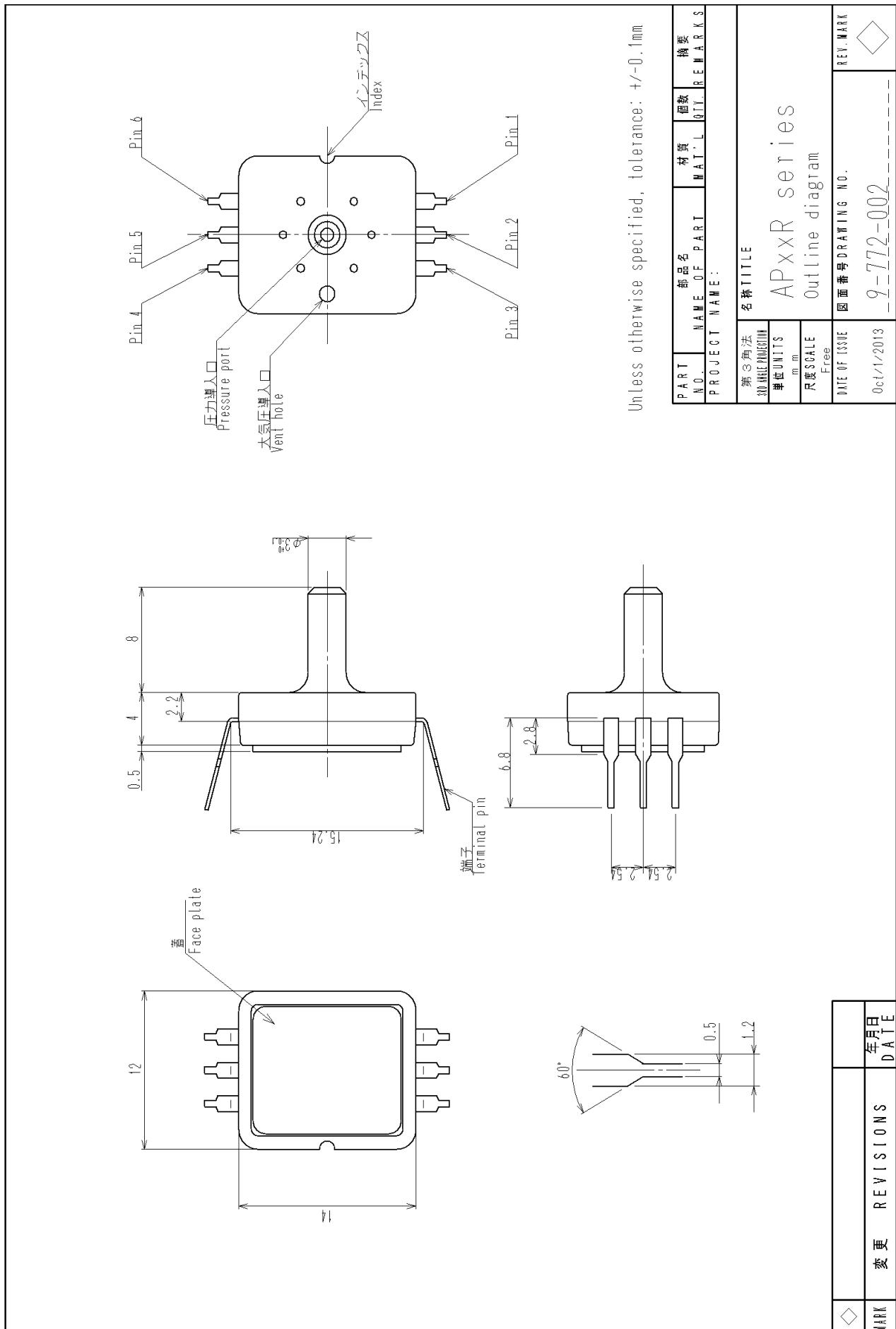

PART NO.	部品名	材質	図数	概要
NAME OF PART	MAT'L QTY.	REMARKS		
PROJECT NAME:				
名称TITLE				
APxxR series				
Outline diagram				
第3角法 30度角法 単位UNITS mm				
尺変SCALE Free				
DATE OF ISSUE	図面番号DRAWING NO.			
Oct/1/2013	9-772-002			
MARK	変更	REVISIONS	年月日 DATE	REV. MARK
◇				◇

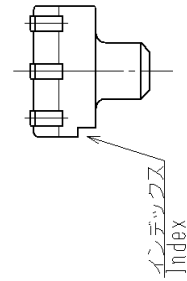
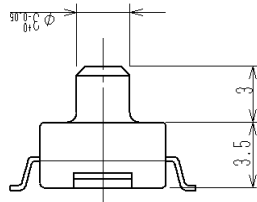
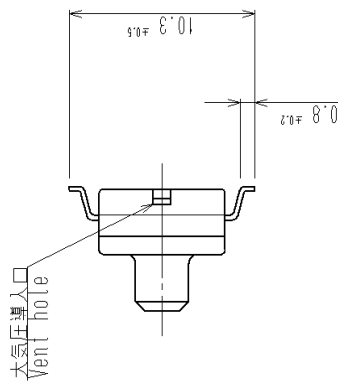
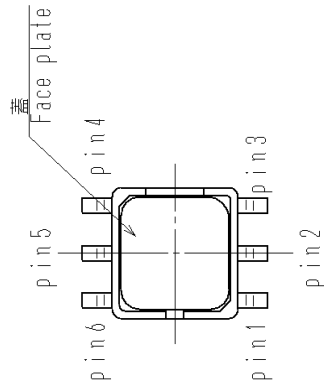
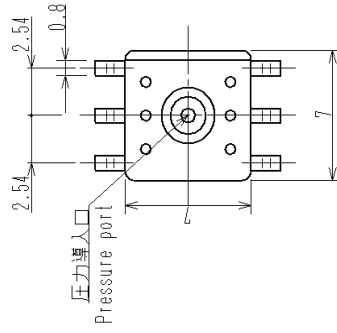

Unless otherwise specified, tolerance: ± 0.1 mm

PART NO.	部品名	材質	個数	備考
PROJECT NAME:				
名称TITLE				
AGxx3 series				
Outline diagram				
第3角法 ANGLE METHOD				
単位UNITS mm				
尺度SCALE Free				
DATE OF ISSUE	図面番号DRAWING NO.			REV. MARK
0c1/1/2013	9-772-003			◇

MARK	変更	REVISIONS	年月日
			DATE

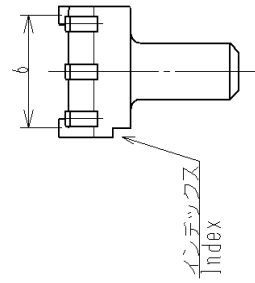
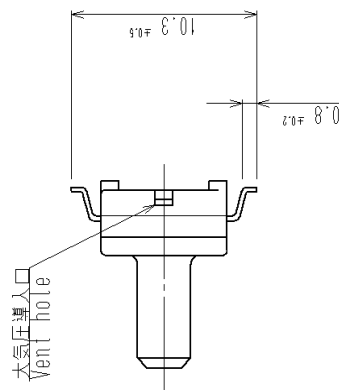
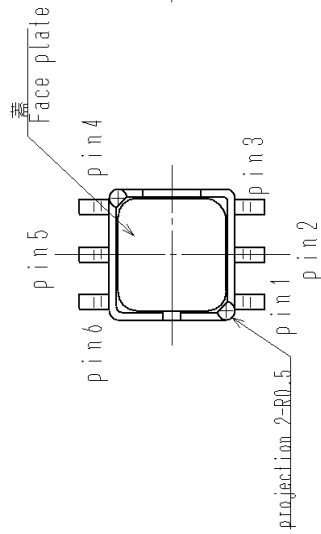
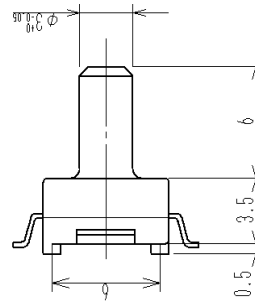
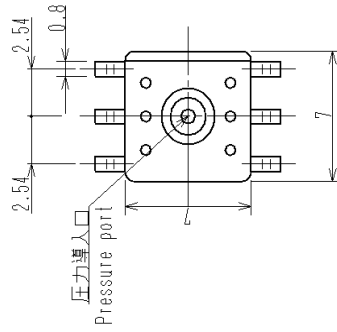

Unless otherwise specified, tolerance: $\pm 0.1\text{mm}$

PART NO.	部品名	材質	個数	備考
PROJECT NAME:				
名称TITLE				
AGxx6 series				
Outline diagram				
図面番号DRAWING NO.				
9-772-004				
REV. MARK				
◇				

MARK	変更	REVISIONS	年月日
			DATE

Headquarter Switzerland:
Angst+Pfister Sensors and Power AG

Thurgauerstrasse 66
CH-8050 Zurich
Phone +41 44 877 35 00
sensorsandpower@angst-pfister.com

Office Germany:
Angst+Pfister Sensors and Power
Deutschland GmbH
Edisonstraße 16
D-85716 Unterschleißheim
Phone +49 89 374 288 87 0
sensorsandpower.de@angst-pfister.com



We are here for you. Addresses and Contacts.

Sales Germany & Austria

Geometrical sensors
Other products

Kurt Stritzelberger
Phone +49 89 374 288 87 22
kurt.stritzelberger@angst-pfister.com

Pressure sensors
Other products

Gerhard Vetter
Phone +49 89 374 288 87 26
gerhard.vetter@angst-pfister.com

Gas sensors and modules

Peter Felder
Phone +41 44 877 35 05
peter.felder@angst-pfister.com

Sales Switzerland & Liechtenstein

Postcode 3000 – 9999

Basil Frei
Phone +41 44 877 35 18
basil.frei@angst-pfister.com

Postcode 1000 – 2999

Christian Mohrenstecher
Phone +41 76 444 57 93
christian.mohrenstecher@angst-pfister.com

Sales International Key Accounts

Peter Felder
Phone +41 44 877 35 05
peter.felder@angst-pfister.com

Sales Other Countries / Product Management

Pressure Sensors
Load Cells

Philipp Kistler
Phone +41 44 877 35 03
philipp.kistler@angst-pfister.com

Gas sensors
Gas sensor modules

Dr. Thomas Clausen
Phone +49 89 374 288 87 24
thomas.clausen@angst-pfister.com

Flow / Level / Medical products

Dr. Adriano Pittarelli
Phone +49 89 374 288 87 67
adriano.pittarelli@angst-pfister.com

Power supplies

Sebastiano Leggio
Phone +41 44 877 35 06
sebastiano.leggio@angst-pfister.com

Linear position sensors
Angle sensors

Eric Letsch
Phone +41 44 877 35 14
eric.letsch@angst-pfister.com

Accelerometers
Sensor elements

Christoph Kleye
Phone +49 89 374 288 87 61
christoph.kleye@angst-pfister.com

Drive technology
CH Postcode 5000 – 9999 / DE

Roman Homa
Phone +41 76 444 00 86
roman.homa@angst-pfister.com

Drive technology
CH Postcode 1000 – 4999 / AT / IT / FR

Christian Mohrenstecher
Phone +41 76 444 57 93
christian.mohrenstecher@angst-pfister.com

Harald Thomas
Phone +49 89 374 288 87 23
harald.thomas@angst-pfister.com